

1250 ISO -  $d_1 \times L_1$

Kuglekurv bestilles separat.

$d_1$	L	$d_3$	$d_2$	$L_1$	Pris
10-11 -12	40	22	14-15 -16	23	
				30	
				37	
15-16	45	28	21-22	23	
				60	
				37	
				47	
	56			60	
	71			60	
19-20	45	32	25-26	23	
				30	
				37	
				47	
				60	
	56			77	
	71			77	
	95			77	
24-25	45	40	30-31	23	

$d_1$	L	$d_3$	$d_2$	$L_1$	Pris
24-25	45	40	30-31	30	
	37				
	47				
	60				
	56			77	
	71			77	
	95			77	
30-32	45	48	38-40	30	
				37	
				47	
				60	
				77	
	50			95	
	56			95	
	71			95	
	95			95	
	120			95	
38-40	45	58	46-48	30	
				37	
				47	
				60	
	50			60	
	63			60	
	80			60	

$d_1$	L	$d_3$	$d_2$	$L_1$	Pris
38-40	95	58	46-48	77	
	120				
	95				
	140			120	
48-50	50	70	56-58	37	
	63				
	47				
	60				
	77				
	80			77	
	95			77	
	120			95	
	140			120	
60-63	95	85	68-71	60	
	77				
	95				
	120			120	
	140			120	
80	140	105	92	120	

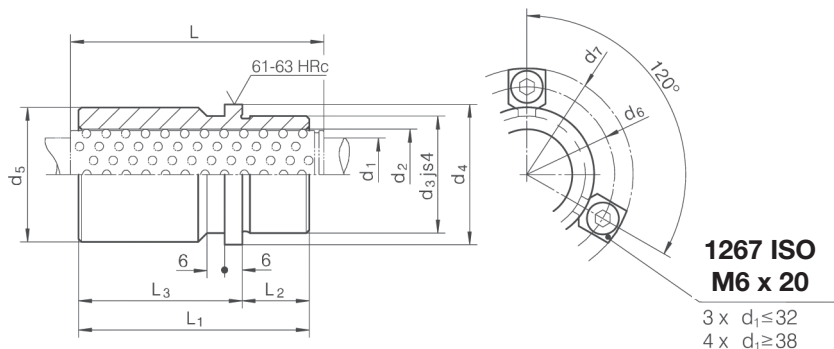

Kuglekurv bestilles separat.

$d_1$	L	L <sub>1</sub>	L <sub>2</sub>	L <sub>3</sub>	$d_7$	$d_6$	$d_5$	$d_4$	$d_3$	$d_2$	Pris
19 - 20	71	59	23	36	64,7	52	39	40	32	25-26	
24 - 25	95	79		56	72,7	60	46	48	40	30-31	
30 - 32	120	93	30	63	79,7	67	53	56	48	38-40	
38 - 40		108	37	71	89,7	77	63	66	58	46-48	
48 - 50	140	127	47	80	103,7	91	77	80	70	56-58	
60 - 63	160	150	60	90	118,7	106	92	95	85	68-71	
80					141,7	129	115	118	105	92	

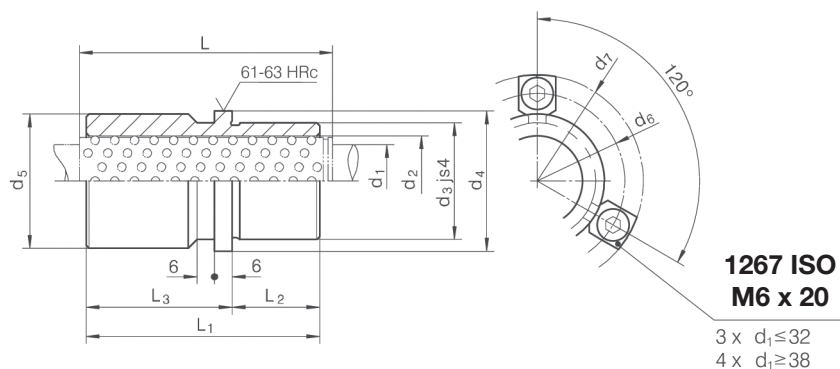

Kuglekurv bestilles separat.

$d_1$	L	L <sub>1</sub>	L <sub>2</sub>	L <sub>3</sub>	$d_7$	$d_6$	$d_5$	$d_4$	$d_3$	$d_2$	Pris
24-25	95	80	30	50	72,7	60	46	48	40	30-31	
30-32	120	93	37	56	79,7	67	53	56	48	38-40	
38-40	140	110	47	63	89,7	77	63	66	58	46-48	
48-50	160	131	60	71	103,7	91	77	80	70	56-58	

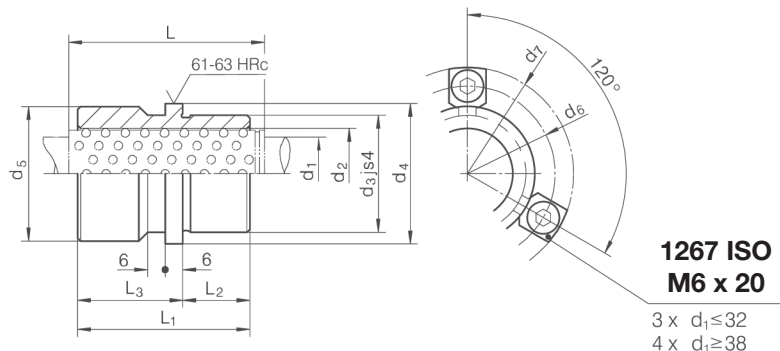

Kuglekurv bestilles separat.

$d_1$	L	$L_1$	$L_2$	$L_3$	$d_7$	$d_6$	$d_5$	$d_4$	$d_3$	$d_2$	Pris
19 - 20	56	42	23	20	64,7	52	39	40	32	25-26	
24 - 25	71	59		36	72,7	60	46	48	40	30-31	
30 - 32	95	75	30	45	79,7	67	53	56	48	38-40	
38 - 40	105	82	37		89,7	77	63	66	58	46-48	
48 - 50	120	97	47	50	103,7	91	77	80	70	56-58	
60 - 63	140	116	60	56	118,7	106	92	95	85	68-71	
80		120		60	141,7	129	115	118	105	92	

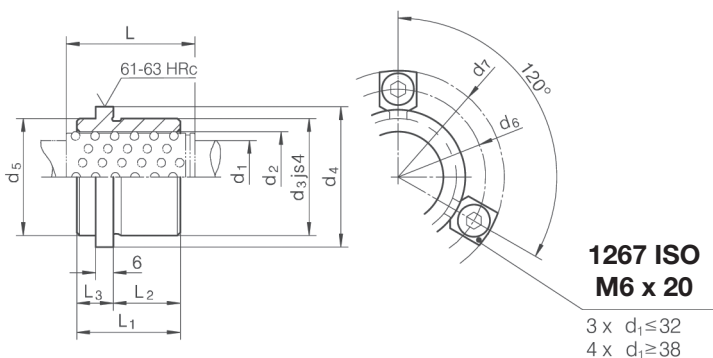

Kuglekurv bestilles separat.

$d_1$	L	$L_1$	$L_2$	$L_3$	$d_7$	$d_6$	$d_5$	$d_4$	$d_3$	$d_2$	Pris
19 - 20	45	35	23	12	64,7	52	32	40	32	25-26	
24 - 25					72,7	60	40	48	40	30-31	
30 - 32	56	42	30	15	79,7	67	48	56	48	38-40	
38 - 40	63	52	37	18	89,7	77	58	66	58	46-48	
48 - 50	80	65	47	20	103,7	91	70	80	70	56-58	
60 - 63	95	80	60	20	118,7	106	85	95	85	68-71	
80	120				141,7	129	105	118	105	92	

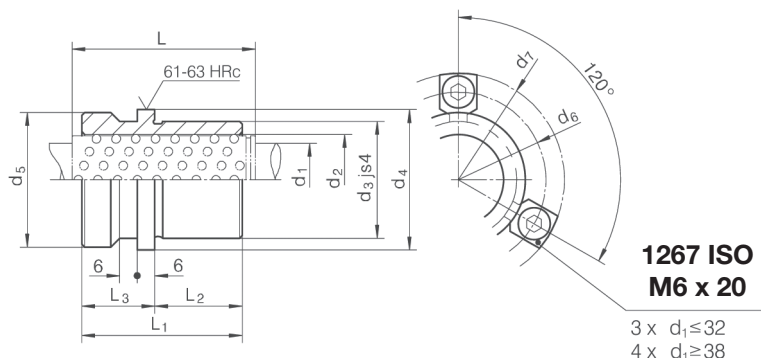

Kuglekurv bestilles separat.

d <sub>1</sub>	L	L <sub>1</sub>	L <sub>2</sub>	L <sub>3</sub>	d <sub>7</sub>	d <sub>6</sub>	d <sub>5</sub>	d <sub>4</sub>	d <sub>3</sub>	d <sub>2</sub>	Pris
24-25	71	55	30	25	72,7	60	46	48	40	30-31	
30-32	80	69	37	32	79,7	67	53	56	48	38-40	
38-40	95	79	47		89,7	77	63	66	58	46-48	
48-50	120	96	60	36	103,7	91	77	80	70	56-58	

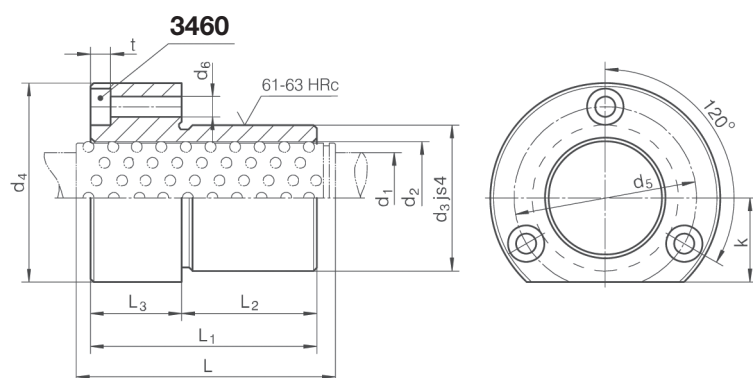

Kuglekurv bestilles separat.

d <sub>1</sub>	L	L <sub>1</sub>	L <sub>2</sub>	L <sub>3</sub>	t	k	d <sub>6</sub>	d <sub>5</sub>	d <sub>4</sub>	d <sub>3</sub>	d <sub>2</sub>	Pris
19 - 20	71	52	37	15	4,6	18	4,5	40	50	32	25-26	
24 - 25		62		25	5,7	23	5,5	50	63	40	30-31	
30 - 32	80	72	47	30	6,8	33	6,6	58	72	48	38-40	
38 - 40	95	77						70	85	58	46-48	
48 - 50	120	102	60	42	9	38	9	86	104	70	56-58	
60 - 63								100	120	85	68-71	
80	140	125	75	50	11	56	11	125	148	105	92	

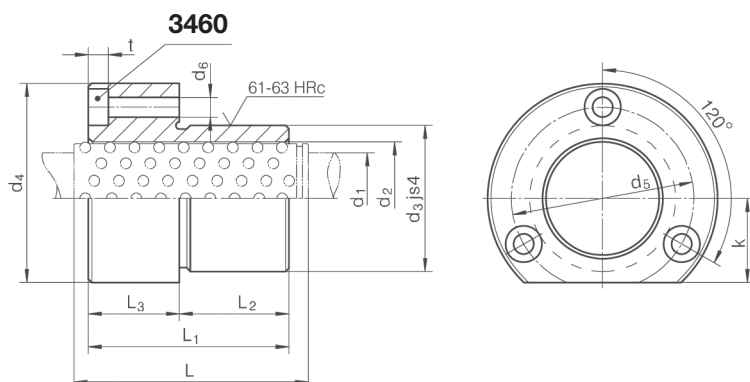

1252.2 ISO - d<sub>1</sub>

Kuglekurv bestilles separat.

d <sub>1</sub>	L	L <sub>1</sub>	L <sub>2</sub>	L <sub>3</sub>	t	k	d <sub>6</sub>	d <sub>5</sub>	d <sub>4</sub>	d <sub>3</sub>	d <sub>2</sub>	Pris
15-16	45	36	30	6	3,4	15	4,5	35	45	28	21-22	
19-20	56	45		15	4,6	18		40	50	32	25-26	
24-25	71	55	37	25	5,7	23	5,5	50	63	40	30-31	
30-32		62						58	72	48	38-40	
38-40	80	67	47	30	6,8	33	6,6	70	85	58	46-48	
48-50	95	89						42	9	38	9	
60-63			46	100	120	85	68-71					

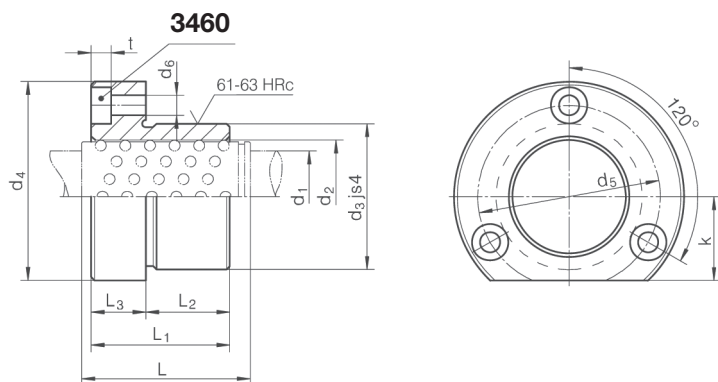

1252.3 ISO - d<sub>1</sub>

Kuglekurv bestilles separat.

d <sub>1</sub>	L	L <sub>1</sub>	L <sub>2</sub>	L <sub>3</sub>	t	k	d <sub>6</sub>	d <sub>5</sub>	d <sub>4</sub>	d <sub>3</sub>	d <sub>2</sub>	Pris
12	40	25	16	9	4,6	13	4,5	33	43	26	16	
15-16	45	29	23	6	3,4	15		35	45	28	21-22	
19-20		38					40	50	32	25-26		
24-25	56	45	30	15	5,7	23	5,5	50	63	40	30-31	
30-32								28	58	72	48	
38-40	63	55	37	25	6,8	33	6,6	70	85	58	46-48	
48-50	80	62						9	38	9	86	