

H	M
12,5	M6

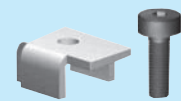

1267 ISO - M

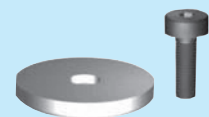
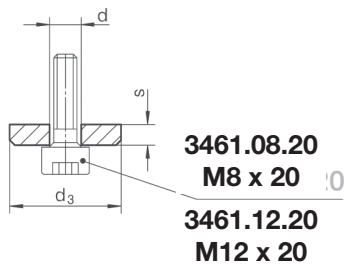
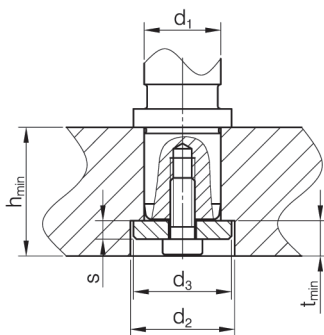

1268 ISO - d<sub>3</sub>

d <sub>1</sub>		s	d	d <sub>2</sub>	d <sub>3</sub>	t <sub>min</sub>	h <sub>min</sub>
1210	1220						
15-16	-	6	9	24	22	11,5	35
19-20	19-20			27	25		42
24-25	24-25			34	32		49
30-32	30-32			42	40		59
38-40	38-40			52	50		80
48-50	48-50			62	60		
60-63	60-63	72	70				
80	80	12	13	95	93	20,5	80