

1240 ISO - $d_1 \times L_1$

d_1	d_2	L_1	Pris
15-16	28	23	
		30	
		37	
		47	
		60	
19-20	32	23	
		30	
		37	
		47	
		60	
24-25	40	23	
		30	
		37	
		47	
		77	

d_1	d_2	L_1	Pris
24-25	40	60	
		77	
30-32	48	30	
		37	
		47	
		60	
		77	
38-40	58	95	
		30	
		37	
		47	
		60	
		77	
		95	
		120	
		120	
		120	

d_1	d_2	L_1	Pris
40-50	70	37	
		47	
		60	
		77	
		95	
60-63	85	120	
		60	
		77	
80	105	95	
		120	
		60	
		110	
		120	

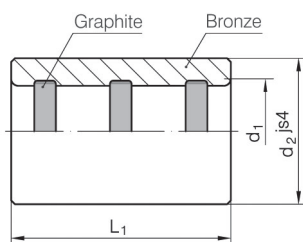

1240.1 ISO - $d_1 \times L_1$

d_1	d_2	L_1	Pris
10-11-12	22	23	
		30	
		37	
15-16	28	23	
		30	
		37	
		47	
		60	
19-20	32	23	
		30	
		37	
		47	
		60	
24-25	40	23	
		30	

d_1	d_2	L_1	Pris
24-25	40	37	
		47	
		60	
		77	
30-32	48	30	
		37	
		47	
		60	
		77	
38-40	58	30	
		37	
		47	
		60	
		77	
		95	

d_1	d_2	L_1	Pris
38-40	58	120	
48-50	70	37	
		47	
		60	
		77	
60-63	85	95	
		120	
		60	
80	105	77	
		95	
		120	
		60	
		110	
		120	

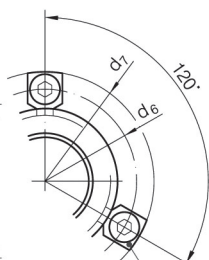
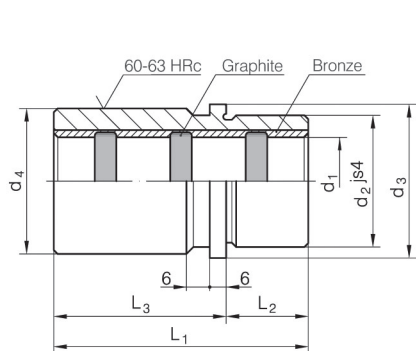

1267 ISO
M6 x 20

3 x $d_1 \leq 32$
4 x $d_1 \geq 38$



1241.1 ISO - d_1

d_1	L_1	L_2	L_3	d_7	d_6	d_4	d_3	d_2	Pris
19 - 20	59	23	36	64,7	52	39	40	32	
24 - 25	79	23	56	72,7	60	46	48	40	
30 - 32	93	30	63	79,7	67	53	56	48	
38 - 40	108	37	71	89,7	77	63	66	58	
48 - 50	127	47	80	103,7	91	77	80	70	
60 - 63	150	60	90	118,7	106	92	95	85	
80	150	60	90	141,7	129	115	118	105	

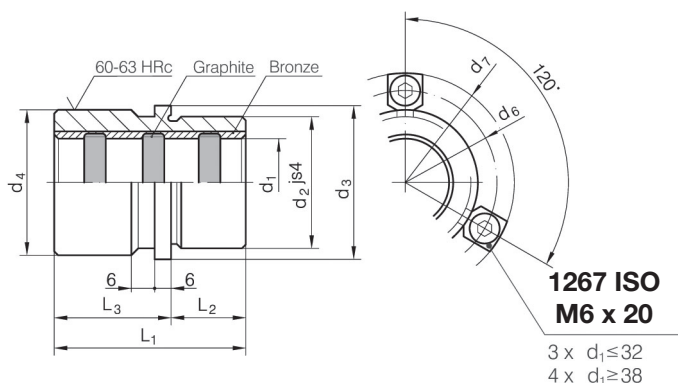

d ₁	L ₁	L ₂	L ₃	d ₇	d ₆	d ₄	d ₃	d ₂	Pris
19 - 20	43		20	64,7	52	39	40	32	
24 - 25	59	23	36	72,7	60	46	48	40	
30 - 32	75	30	45	79,2	67	53	56	48	
38 - 40	82	37	45	89,7	77	63	66	58	
48 - 50	97	47	50	103,7	91	77	80	70	
60 - 63	116	60	56	118,7	106	92	95	85	
80	120	66	60	141,7	129	115	118	105	

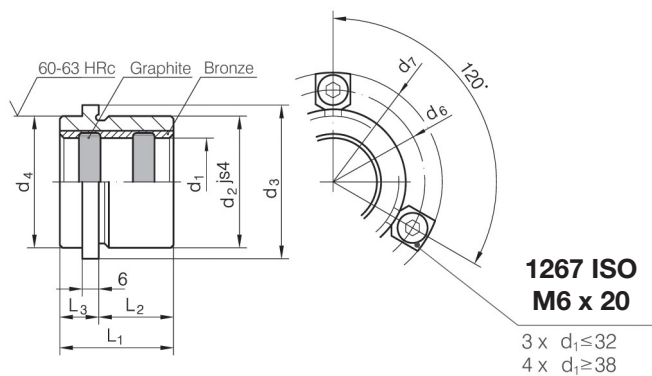

d ₁	L ₁	L ₂	L ₃	d ₇	d ₆	d ₄	d ₃	d ₂	Pris
19 - 20				64,7	52	32	40	32	
24 - 25	36	23	20	72,7	60	40	48	40	
30 - 32	42	30		79,2	67	48	56	48	
38 - 40	52	37	15	89,7	77	58	66	58	
48 - 50	65	47	18	103,7	91	70	80	70	
60 - 63				118,7	106	85	95	85	
80	80	60	20	141,7	129	105	118	105	

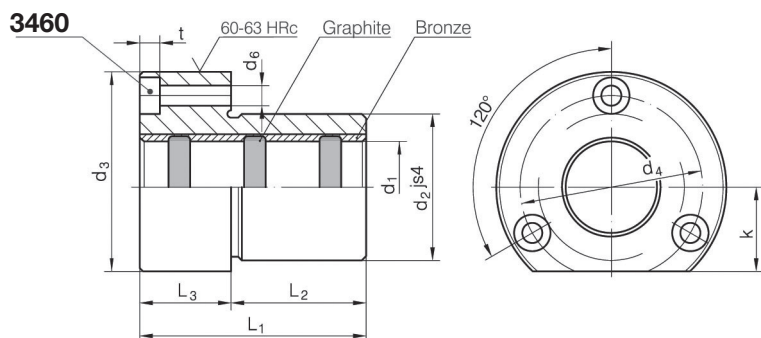

d ₁	L ₁	L ₂	L ₃	t	k	d ₆	d ₄	d ₃	d ₂	Pris
19 20	52	37	15	4,6	18	4,5	40	50	32	
24 25	62									
30 32	72	47	30	6,8	33	6,6	70	85	48	
38 40	77									
48 50	102	60	42	9	46	9	100	120	85	
60 63										
80										

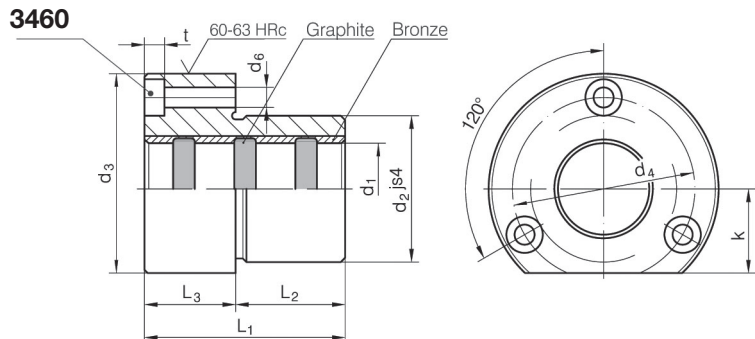

d ₁	L ₁	L ₂	L ₃	t	k	d ₆	d ₄	d ₃	d ₂	Pris
15 16	36	30	6	3,4	15	4,5	35	45	28	
19 20	45									
24 25	55	25	5,7	23	5,5	50	63	40		
30 32	62								37	
38 40	67	47	42	9	38	9	86	104		
48 50	89								47	
60 63										

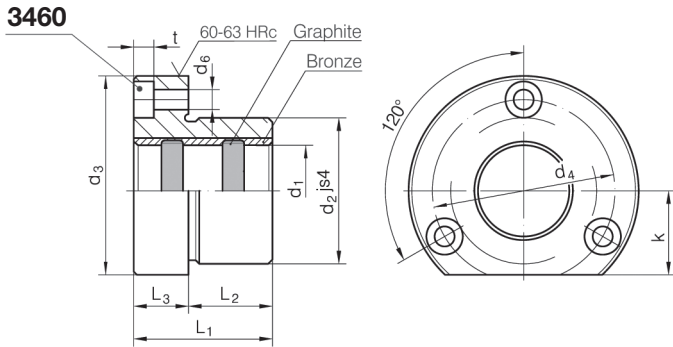

1242.3 ISO - d₁

d ₁	L ₁	L ₂	L ₃	t	k	d ₆	d ₄	d ₃	d ₂	Pris
15 - 16	29	23	6	3,4	15	4,5	35	45	28	
19 - 20	38			4,6						
24 - 25	45	30	15	5,7	23	5,5	50	63	40	
30 - 32				28	58	72	48			
38 - 40	55	37	25	6,8	33	6,6	70	85	58	
48 - 50	62			9	38	9	86	104	70	