

POWER TOOLS bronzebøsning

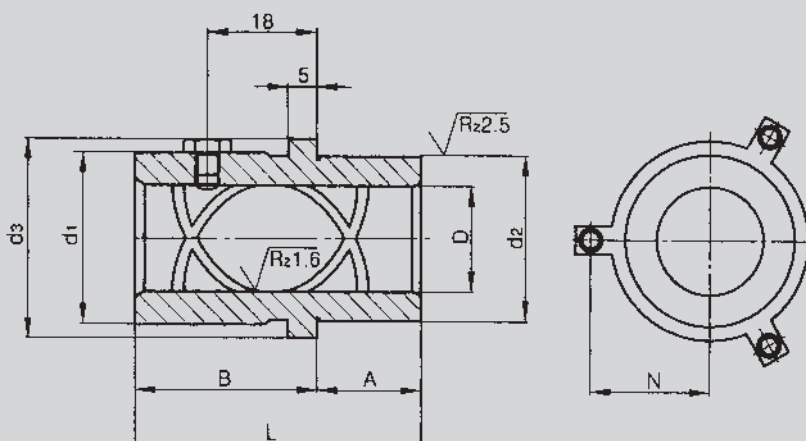

Ståltipe 16CRNi4
Bronzeforet, slebet og lappet.
Hårdhed 60 - 62 HRC
Hultolerance for boring: H6

DH4	18	25	32	40	50	63
d1	31	41	50	60	76	89
d2h4	28	38	45	54	65	81
d3	34	44	53	63	79	92
N	20,5	25,5	31,5	36,5	44,5	51
Lang model						
A	18	23	26	30	35	48
B	52	57	64	70	75	82
L	70	80	90	100	110	130
Pris						
Standard model						
A	18	23	26	30	35	48
B	32	32	34	37	40	42
L	50	55	60	67	75	90
Pris						
Kort model						
A	18	23	30	38	48	61
B	13	13	13	13	13	13
L	31	36	43	51	61	74
Pris						

Alle priser skal forstås fritblivende og excl. Moms

POWER TOOLS ApS

Stengårdsvej 19 - DK-4340 Tølløse - Tlf. 59194058 - www.power-tools.dk - Mail: info@power-tools.dk